

# CHAMPION VALVES, INC.

DUAL DISC SPRING LOADED WAFER CHECK VALVES

QUALITY PRODUCTS, SERVICE & RELIABILITY

Disturbed By:  
**POWER PLANT SUPPLY CO**

ONTARIO, CANADA 416 752 3339  
ATLANTIC, CANADA  
Nova Scotia 902 435 9899  
Newfoundland Labrador 709 747 7650  
[www.powerplantenergy.com](http://www.powerplantenergy.com)  
[www.powerplantsupplyco.com](http://www.powerplantsupplyco.com),  
[info@powerplantsupplyco.com](mailto:info@powerplantsupplyco.com)

CHAMPION WAFER CHECK VALVES · SIZE RANGE: 2" — 48" · ASME CLASS: 125 — 2500



MATERIALS: CAST IRON · CARBON STEEL · STAINLESS STEEL · ALUMINUM BRONZE · ALLOY 20 · MONEL · NICKEL



# CHAMPION VALVES, INC.

## DUAL DISC SPRING LOADED WAFER CHECK VALVES

FEATURES	BENEFITS
<ul style="list-style-type: none"><li>• Light weight, versatile design — 80% to 90% less than conventional full-body swing check valves</li></ul>	<ul style="list-style-type: none"><li>• Simplifies piping</li><li>• Reduces thermal and seismic considerations</li><li>• Optimizes space utilization</li><li>• Lowers installation costs</li><li>• Reduces pipe supports</li><li>• Requires less number of man-hours</li></ul>
<ul style="list-style-type: none"><li>• Dual Disc open to 80 degrees</li></ul>	<ul style="list-style-type: none"><li>• Low cracking pressure and overall pressure drop</li><li>• Ensures positive closure</li></ul>
<ul style="list-style-type: none"><li>• Spring-loaded discs calculated to increase the responsiveness of the disc</li></ul>	<ul style="list-style-type: none"><li>• Alleviates water hammer and resultant damaging effects</li></ul>
<ul style="list-style-type: none"><li>• Extended long-leg spring</li></ul>	<ul style="list-style-type: none"><li>• Prevents seat wear caused by scrubbing</li></ul>

### GENERAL APPLICATION

- General service piping systems
- Water, oil, gasoline
- Gas (compressible gases)
- Air (compressed air and blower)

### INSTALLATION

Champion wafer check valves are designed for installation in flanged piping systems, between two flanges. Valves may be installed in vertical or horizontal piping. Care must be taken to always install the valves with the shafts in a vertical position when installing in a horizontal pipeline. Vertical up flow is always a good installation. Consult factory for vertical down flow.

To insure maximum service life it is recommended to have 5 pipe diameters of straight pipe in front of the valve. Champion wafer check valves are designed to provide long service life if the velocity is kept within the flow rate shown in the table on page 7 and if a minimum of 5 pipe diameters of straight pipe is maintained downstream from a likely cause of turbulence (i.e., pump discharge, reducers or elbows).

### INDUSTRY STANDARDS

- ASME B16.1, B16.5, B16.34, B16.47 and B31.1
- API 594 and 598 • MSS-SP-25, MSS-SP-55
- API 6A and 6D (as applicable) • MSS-SP-61 (standard for the resilient seated, metal seated when required)



# FIGURE NUMBER INFORMATION

## ASME PRESSURE CLASS

12	=	125 Class
15	=	150 Class
25	=	250 Class
30	=	300 Class
40	=	400 Class
60	=	600 Class
90	=	900 Class
150	=	1500 Class
250	=	2500 Class

*API Pressure Class available.*

## BODY & DISCS

ORDERING LETTER	MATERIAL	OPERATING TEMPERATURE
A	Aluminum Bronze	ASTM B148, Alloy 952; BS 1400, Alloy AB2
B	Bronze	ASTM B62, C83600
S	316 Stainless Steel	ASTM A351, Gr. CF8M
J	410 Stainless Steel	ASTM A217, Gr. CA15 (12% Cr)
F	Alloy® 20	ASTM A351, Gr. CN7M
G	Cast Iron	ASTM A126; BS 1452, Gr.220
H	Hastelloy® C	ASTM A494, Gr. CW2M
M	Monel®	ASTM A494, Gr. M-35-1
N	Nickel	ASTM A494, Gr. CZ-100
C	Carbon Steel	ASTM A216, Gr. WCB
K	317 Stainless Steel	ASTM A351, Gr. CG8M
D	Duplex	ASTM A351, Gr. CD4MCu
T	304 Stainless Steel	ASTM A351, Gr. CF8

## SEAT

ORDERING LETTER	MATERIAL	OPERATING TEMPERATURE	
		°C	°F
E	EPDM	-29 to 149	-20 to 300
B	Buna-N	-23 to 121	-10 to 250
P	Metal (Same as Body)	per ASME code	per ASME code
S	316 Stainless Steel overlay	-267 to 537	-450 to 1000+
J	410 Stainless Steel overlay	-267 to 537	-450 to 1000+
V	Viton®	-18 to 204	0 to 400

## SPRING

ORDERING LETTER	MATERIAL	OPERATING TEMPERATURE	
		°C	°F
S	316 SS	260	500
W	Inconel®	371	700
X	Inconel® X-750	593	1100
M	Monel®	232	450

## END CONNECTION

ORDERING LETTER	CONNECTIONS
R	Serrated Raised Face
P	Plain Face
J	Ring Joint

## BODY CONFIGURATION

DESIGNATION NUMBER	CONFIGURATION
None (Blank)	Wafer style, inserted between mating flanges with studs spanning entire length
1	Lug design with threaded holes bolted from each end
2	Lug design with through-bolt holes to protect studs
3	Double flanged design with valve flanges bolted to individual like flanges

**ORDER EXAMPLE:** Specifications for 6"(150mm), Champion Wafer Check Style CV, ASME 300 Class, 316 Stainless Steel Body with 316 SS Discs, 316 SS Seat, Inconel X-750 Spring, Raised Face End Connection, with Through Lug Body:

**6CV30 - SSPX - R2**

SIZE	STYLE	PRESSURE CLASS	BODY	DISC	SEAT	SPRING	END CONNECTION	BODY CONFIGURATION	MODIFICATION NUMBER
6"	CV	30	S	S	P	X	R	2	Assigned by Factory

# STYLE CV INSTALLATION DIMENSIONS \*

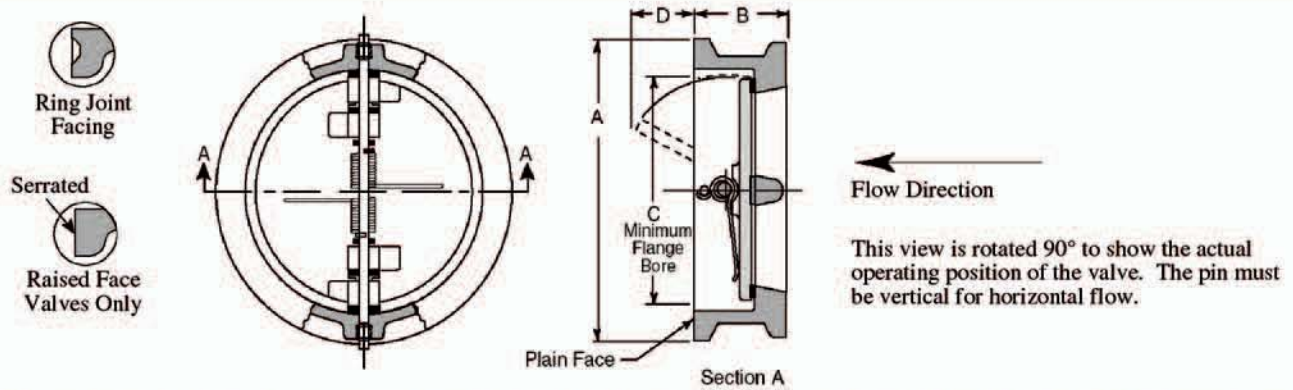

Dimensions for lug and double flange body styles and bolting requirements are available upon request.

## ASME CLASS 125 (Cast Iron Valves Only)

Size		A		B		C		D		Weight	
in	mm	in	mm	in	mm	in	mm	in	mm	lbs	kg
2"	50	4 1/8	105	2 1/8	54	2 1/16	52	-	-	4	1.8
2 1/2"	65	4 7/8	124	2 1/8	54	2 15/32	63	-	-	6	2.7
3"	80	5 3/8	137	2 1/4	57	3 1/16	78	5/8	16	7	3.2
4"	100	6 7/8	175	2 1/2	64	4	102	1	25	12	5.4
5"	125	7 3/4	197	2 3/4	70	5	127	1 5/16	33	15	6.8
6"	150	8 3/4	222	3	76	6 1/16	154	1 15/16	35	20	9
8"	200	11	279	3 3/4	95	8	203	3 7/16	54	40	18
10"	250	13 3/8	340	4 1/4	108	10	254	3 3/8	70	65	29
12"	300	16 1/8	410	5 5/8	143	11 15/16	303	3 9/16	83	110	50
14"	350	17 3/4	451	7 1/4	184	12 1/2	318	3 1/16	83	183	83
16"	400	20 1/4	514	7 1/2	191	15	381	4 1/4	113	255	116
18"	450	21 5/8	549	8	203	16 7/8	429	5 3/8	137	315	143
20"	500	23 7/8	606	8 3/8	213	18 13/16	478	6 3/16	160	380	173
24"	600	28 1/4	718	8 3/4	222	22 5/8	575	8 1/4	210	575	261
30"	750	34 3/4	883	12	305	29 1/4	743	9 9/16	229	1070	486
36"	900	41 1/4	1048	14 1/2	368	35	889	12 5/16	303	1962	892
42"	1050	48	1219	17	432	41	1041	15	381	2800	1270
48"	1200	54 1/2	1384	20 5/8	524	47	1194	16 3/4	425	3920	1178

## ASME CLASS 150

Size		A		B		C		D		Weight	
in	mm	in	mm	in	mm	in	mm	in	mm	lbs	kg
2"	50	4 1/8	105	2 3/8	60	1 15/16	49	-	-	6	3
2 1/2"	65	4 7/8	124	2 5/8	67	2 11/32	60	-	-	10	5
3"	80	5 3/8	137	2 7/8	73	2 29/32	74	1/4	6	13	6
4"	100	6 7/8	175	2 7/8	73	3 27/32	97	5/8	16	17	8
5"	125	7 3/4	197	3 3/8	86	4 13/16	122	7/8	22	27	12
6"	150	8 3/4	222	3 7/8	98	5 3/4	146	1 3/8	35	35	16
8"	200	11	279	5	127	7 5/8	194	2 1/8	54	70	32
10"	250	13 3/8	340	5 3/4	146	9 9/16	243	2 3/4	70	106	48
12"	300	16 1/8	410	7 1/8	181	11 3/8	289	3 1/4	83	172	78
14"	350	17 3/4	451	7 1/4	184	12 1/2	318	3 1/4	83	200	91
16"	400	20 1/4	514	7 1/2	191	15	381	4 7/16	113	275	125
18"	450	21 5/8	549	8	203	16 7/8	429	5 3/8	137	315	143
20"	500	23 7/8	606	8 5/8	219	18 13/16	478	6 5/16	160	435	197
24"	600	28 1/4	718	8 3/4	222	22 5/8	575	8 1/4	210	620	281
26"	650	30 1/2	775	14	356	24 1/4	616	8	203	1555	705
30"	750	34 3/4	883	12	305	29 1/4	743	9	229	1230	558
36"	900	41 1/4	1048	14 1/2	368	35	889	12	303	2017	915
42"	1050	48	1219	17	432	41	1041	15	381	2800	1270
48"	1200	54 1/2	1384	20 5/8	524	47	1194	16 3/4	425	3920	1178

\*Approximate weights and dimensions—Apply for certified drawings. Dimensions available with DIN, JIS, AS and ISO. Sizes above 24" per ASME B16.47 Series A. Series B available if required.

# STYLE CV INSTALLATION DIMENSIONS (Continued) \*

## ASME CLASS 250

Size		A		B		C		D		Weight	
in	mm	in	mm	in	mm	in	mm	in	mm	lbs	kg
2"	50	4 3/8	111	2 1/8	54	1 15/16	49	3/32	2	5	2.3
2 1/2"	65	5 1/8	130	2 3/8	60	2 11/32	60	3/8	10	11	5
3"	80	5 7/8	149	2 5/8	67	2 29/32	74	9/16	14	11	5
4"	100	7 1/8	181	2 5/8	67	3 13/16	96	9/16	14	14	6.4
5"	125	8 1/2	216	3 1/4	83	4 13/16	122	1	25	29	13.2
6"	150	9 7/8	251	3 3/4	95	5 3/4	146	1 1/2	38	35	16
8"	200	12 1/8	308	5	127	7 5/8	194	2 1/8	54	75	34
10"	250	14 1/4	362	5 1/2	140	9 9/16	243	3 1/16	80	113	51
12"	300	16 5/8	422	7 1/8	181	11 3/8	289	3 1/4	83	174	79
14"	350	19 1/8	486	8 3/4	222	12 1/2	318	3 3/16	81	299	136
16"	400	21 1/4	540	9 1/8	232	14 5/16	364	4 1/8	105	380	172
18"	450	23 1/2	597	10 3/8	264	16 7/8	429	4 13/16	122	510	231
20"	500	25 3/4	654	11 1/2	292	17 15/16	456	5 3/8	136	593	269
24"	600	30 1/2	775	12 1/2	318	21 9/16	548	7 1/16	179	1010	458
30"	750	37 1/2	953	14 1/2	368	28 3/4	730	8 13/16	224	1880	853
36"	900	44	1118	19	483	35	889	11 9/16	294	3573	1608
42"	1050	50 3/4	1289	22 3/8	568	41	1041	14 3/4	375	5780	2622
48"	1200	58 3/4	1492	24 3/4	629	47	1194	16 1/2	419	6572	2981

## ASME CLASS 300

Size		A		B		C		D		Weight	
in	mm	in	mm	in	mm	in	mm	in	mm	lbs	kg
2"	50	4 3/8	111	2 3/8	60	1 15/16	49	-	-	7	3
2 1/2"	65	5 1/8	130	2 5/8	67	2 11/32	60	-	-	11	5
3"	80	5 7/8	149	2 7/8	73	2 29/32	74	1/4	6	15	7
4"	100	7 1/8	181	2 7/8	73	3 13/16	96	5/8	16	18	8
5"	125	8 1/2	216	3 3/8	86	4 13/16	122	7/8	22	35	16
6"	150	9 7/8	251	3 7/8	98	5 3/4	146	1 3/8	35	45	20
8"	200	12 1/8	308	5	127	7 5/8	194	2 1/8	54	82	37
10"	250	14 1/4	362	5 3/4	146	9 9/16	243	2 3/4	70	125	57
12"	300	16 5/8	422	7 1/8	181	11 3/8	289	3 1/4	83	200	91
14"	350	19 1/8	486	8 3/4	222	12 1/2	318	3 3/16	81	325	147
16"	400	21 1/4	540	9 1/8	232	14 5/16	364	4 1/8	105	415	188
18"	450	23 1/2	597	10 3/8	264	16 7/8	429	4 13/16	122	555	252
20"	500	25 3/4	654	11 1/2	292	17 15/16	456	5 5/8	143	725	329
24"	600	30 1/2	775	12 1/2	318	21 9/16	548	7 1/16	179	1100	499
26"	650	32 7/8	835	14	356	24 3/8	619	8	203	1605	728
30"	750	37 1/2	953	14 1/2	368	28 3/4	730	9 1/16	230	2050	930
36"	900	44	1118	19	483	35	889	11 3/16	284	3573	1621
42"	1050	50 3/4	1289	22 3/8	568	41	1041	14 3/4	375	5780	2622
48"	1200	58 3/4	1492	24 3/4	629	47	1194	16 1/2	419	6572	2981

## ASME CLASS 600

Size		A		B		C		D		Weight	
in	mm	in	mm	in	mm	in	mm	in	mm	lbs	kg
2"	50	4 3/8	111	2 3/8	60	1 15/16	49	-	-	7	3
2 1/2"	65	5 1/8	130	2 5/8	67	2 11/32	60	1/8	3	11	5
3"	80	5 7/8	149	2 7/8	73	2 29/32	74	1/4	6	15	7
4"	100	7 5/8	194	3 1/8	79	3 13/16	96	7/8	22	26	12
5"	125	9 1/2	241	4 1/8	105	4 13/16	122	1	25	50	22.7
6"	150	10 1/2	267	5 3/8	137	5 3/4	146	1 7/16	36	80	36
8"	200	12 5/8	321	6 1/2	165	7 5/8	194	2	51	135	61
10"	250	15 3/4	400	8 3/8	213	9 9/16	243	2 9/32	58	238	108
12"	300	18	457	9	229	11 3/8	289	3 15/32	88	333	151
14"	350	19 3/8	492	10 3/4	273	12 1/2	318	2 3/4	70	455	206
16"	400	22 1/4	565	12	305	14 5/16	364	4 5/16	110	640	290
18"	450	24 1/8	613	14 1/4	362	16 1/8	410	3 11/16	94	890	404
20"	500	26 7/8	683	14 1/2	368	17 15/16	456	5 5/16	135	1120	508
24"	600	31 1/8	791	17 1/4	438	21 9/16	548	6 9/16	167	2040	925

\* Approximate weights and dimensions—Apply for certified drawings. Dimensions available with DIN, JIS, AS and ISO. Sizes above 24" per ASME B16.47 Series A. Series B available if required.

# STYLE CV INSTALLATION DIMENSIONS (Continued)\*

## ASME CLASS 900

Size		A		B		C		D		Weight	
in	mm	in	mm	in	mm	in	mm	in	mm	lbs	kg
2"	50	5 5/8	143	2 3/4	70	1 11/16	43	-	-	14	6
2 1/2"	65	6 1/2	165	3 1/4	83	2 1/8	54	1/16	2	16	7
3"	80	6 5/8	168	3 1/4	83	2 5/8	67	5/16	8	24	11
4"	100	8 1/8	206	4	102	3 7/16	87	9/16	14	40	18
5"	125	9 3/4	248	-	-	4 5/16	110	-	-	-	-
6"	150	11 3/8	289	6 1/4	159	5 3/16	132	1 1/16	27	115	52
8"	200	14 1/8	359	8 1/8	206	6 13/16	173	1 13/32	36	229	104
10"	250	17 1/8	435	9 1/2	241	8 1/2	216	1 13/16	46	388	176
12"	300	19 5/8	498	11 1/2	292	10 1/8	257	2 5/16	59	540	245
14"	350	20 1/2	521	14	356	11 1/2	292	2	51	926	420
16"	400	22 5/8	575	15 1/8	384	12 13/16	325	2 5/8	67	1152	523
18"	450	25 1/8	638	17 3/4	451	14 7/16	367	2 9/16	65	1318	598
20"	500	27 1/2	699	17 3/4	451	17 15/16	456	5 5/16	135	1426	647
24"	600	33	838	19 1/2	495	21 1/2	546	5 5/8	143	2729	1238

## ASME CLASS 1500

Size		A		B		C		D		Weight	
in	mm	in	mm	in	mm	in	mm	in	mm	lbs	kg
2"	50	5 5/8	143	2 3/4	70	1 11/16	43	-	-	14	6
2 1/2"	65	6 1/2	165	3 1/4	83	2 1/8	54	1/16	2	16	7
3"	80	6 7/8	175	3 1/4	83	2 5/8	67	5/16	8	25	11
4"	100	8 1/4	210	4	102	3 7/16	87	9/16	14	43	20
5"	125	10	254	-	-	4 5/16	110	-	-	-	-
6"	150	11 1/8	283	6 1/4	159	5 3/16	132	1 1/16	27	110	50
8"	200	13 7/8	352	8 1/8	206	6 13/16	173	1 13/32	36	219	99
10"	250	17 1/8	435	9 3/4	248	8 1/2	216	1 11/16	43	397	180
12"	300	20 1/2	521	12	305	10 1/8	257	2 1/4	57	725	329
14"	350	22 3/4	578	14	356	11 1/2	292	2	51	948	430
16"	400	25 1/4	641	15 1/8	384	12 13/16	325	2 5/8	67	1380	627
18"	450	27 3/4	705	18 7/16	468	13 3/4	349	2 11/16	68	1900	863

\*Approximate weights and dimensions—Apply for certified drawings. Dimensions available with DIN, JIS, AS and ISO. Sizes above 24" per ASME B16.47 Series A. Series B available if required.

## PRESSURE DROP CALCULATIONS FOR GAS

Pressure drop for gas media across Champion Wafer Check (in horizontal installation) can be determined using the following equation and Cv and Cracking Pressure shown for each valve size. Additional equations may be necessary in order to calculate the pressure drop.

### AMERICAN STANDARD (Horizontal Installation)

$$\Delta P = \frac{GT}{P} \left( \frac{Q}{1360 C_v} \right)^2 + P_c$$

Where:

- Cv = Flow Coefficient
- G = Specific Gravity of Gas
- P = Inlet Pressure, in psia (psig + 14.7)
- ΔP = Pressure Drop Across Valve, in psi
- Pc = Cracking Pressure
- Q = Gas Flow Rate, in SCFH
- T = Temperature, Absolute (°F + 460)

$$SCFH = ACFH \left( \frac{P}{14.7} \right) \left( \frac{520}{T} \right)$$

Where:

- ACFH = Actual Cubic Feet per Hour
- SCFH = Standard Cubic Feet per Hour

# TECHNICAL DATA

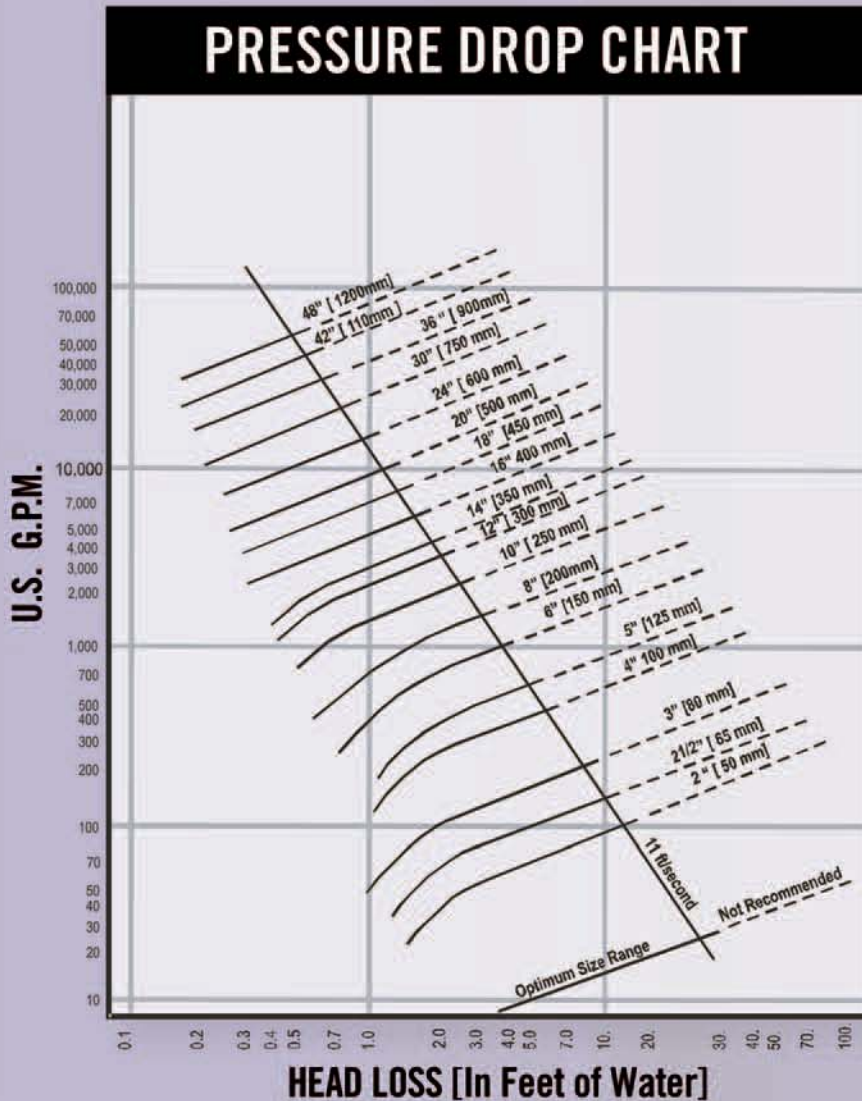

## C<sub>v</sub> & CRACKING PRESSURE

Size	C <sub>v</sub>	Pressure
2"	48	0.220
2.5"	77	0.189
3"	135	0.098
4"	270	0.184
5"	450	0.200
6"	720	0.218
8"	1400	0.162
10"	2600	0.230
12"	3850	0.241
14"	5000	0.230
16"	7250	0.210
18"	10,000	0.138
20"	12,400	0.128
24"	20,400	0.098
30"	38,000	0.099
36"	60,000	0.095
42"	89,000	0.090
48"	124,000	0.088

*Application specific spring torques are available.*

**PRESSURE DROP CHART.** This chart is based on flow of clean water at ambient temperature. Consult our engineering department for pressure drop information for steam, gases or viscous fluids. Consult factory for pressure drop of sizes larger than 48 inches.

### GOOD PIPING PRACTICE

recommends placement of check valves a distance equal to 5 pipe diameters from any turbulence producing device such as elbows, pumps, etc.

### RECOMMENDED FLOW RATE RANGES FOR HORIZONTAL INSTALLATION ONLY

Media	Flow Rate
Liquid	3 to 11 feet/second 0.91 to 3.35 m/second
Gas	20 to 250 feet/second 6.1 to 76.2 m/second

EXCEPTIONAL QUALITY, SERVICE & RELIABILITY



CHAMPION VALVES, INC.

P.O. BOX 12901 · WILMINGTON, N.C. 28405 USA

PHONE: 910.794.5547 · FAX: 910.794.5581 · EMAIL: SALES@WAFERCHECK.COM

VISIT OUR WEBSITE AT: [WWW.WAFERCHECK.COM](http://WWW.WAFERCHECK.COM)

REPRESENTED BY:

