

CANADIAN SUPPLIERS FOR PSI POWER PLANT SUPPLY CO

Engineered Gasket for Xtreme Critical Sealing

Prevent future leaks and blowouts today.

IN CANADA CONTACT POWER PLANT SUPPLY CO
<http://www.powerplantsupplyco.com/contacts.php>



<http://www.powerplantsupplyco.com>



Sealing Gasket for Zero Fugitive Emissions & Extreme Critical Sealing Applications

The LineSeal™ gasket uses proprietary materials to address the regulations associated with fugitive emissions, requirements that are closely monitored and highly sensitive to regulatory agencies today.

LineSeal™ Sealing & Isolating Gaskets

Features

- Extreme, high-reliability sealing and electrical isolation solution for critical service applications.
- Seals and isolates all pressure ratings through ANSI 2500 class and API 15,000 psi service.
- Withstands severe service conditions including vibration, temperature and pressure fluctuations.
- Designed to withstand corrosive environments, including high concentrations of CO₂, H₂S, produced water and aggressive inhibitors.
- Good electrical isolation properties for cathodic protection.
- Pressure-activated seals provide high confidence sealing, eliminates costly leaks and provides a solution for fugitive emissions.
- Gasket is sized to the bore to protect flange faces from media-induced corrosion and flow-induced erosion.
- Prevents turbulent flow at flanged connections.
- Mitigates galvanic corrosion in dissimilar metal flanges.
- High-strength laminate material resists failure due to excess compression.
- Available to match any flange specification (ANSI, ASME, API, MSS, BS, DIN, AS, others).
- Can mate mismatched RTJ with raised-face flanges.

- Easy installation, make up and removal:
 - Sealing system is not sensitive to low bolt loads - providing reliable sealing through a range of bolt stress.
 - Gasket is self-aligning and centering - quick to install and no special tools are required.
- Maintenance-free corrosion-resistant design is resistant to deforming under load.
- Works in Ring Joint Flanges, reducing fluid entrapment, flow induced erosion and media induced corrosion between flanges.

Applications

- H₂S service.
- High pressure flanges.
- Critical service applications.
- High Ph service.
- Locations where one prefers an integral seal element.
- Sealing flanges without dissimilar metal contact that occurs with chevron in spiral-wound type gaskets.

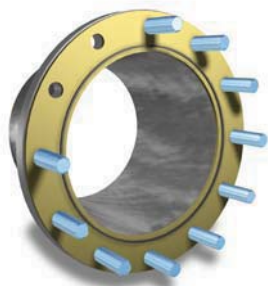
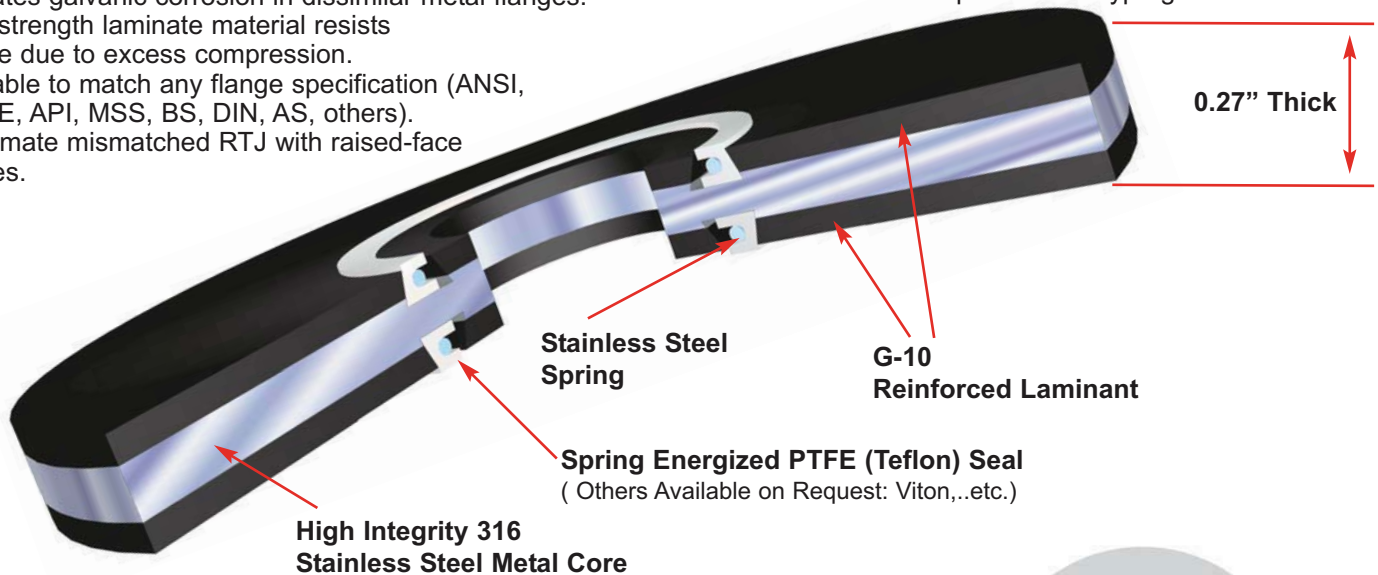

Type E

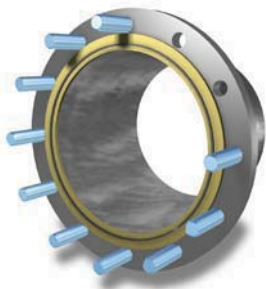

Type F

Sealing element may be positioned anywhere between the I.D. of the gasket and I.D. of the bolt circle.

Note: Type E are custom made to order.

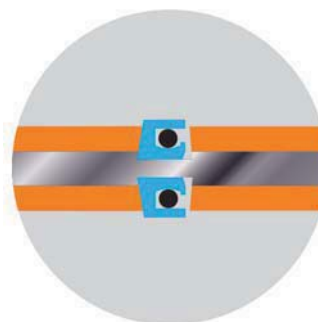

Before Tightening

The flange faces come into contact with the sealing elements, which extend slightly above the surface of the retainer. As the flange is tightened the sealing elements are compressed into the machine groove, developing an initial high unit pressure against the flange faces.

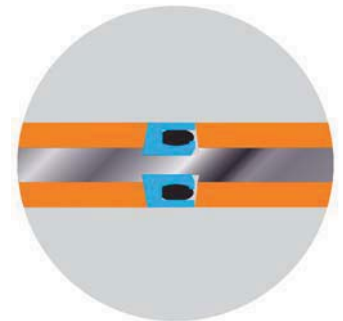

Note: Can work for ring joint flanges reducing fluid entrapment.

After Tightening

The flange faces come into firm contact with the retainer, thus compacting the sealing elements within grooves. At the same time, the unique LineSeal spring energized seal provides elastic memory for polymers not normally associated with this characteristic - resulting in a simple flat gasket with extremely high loading and self energizing characteristics without adverse cold flow problems.

PSI sealing gaskets far exceed the sealing capabilities of flat gaskets.

Here's why....

PSI sealing gaskets consist of a sealing element positioned within a groove on opposite sides of a retainer. Elastic memory characteristics of the confined sealing elements result in near zero "m" and "y" factors making it possible to effect a positive seal without the tremendous bolt loads that are required to crush flat gaskets into a configuration capable of producing a marginal seal, at best.

Y = Compressive load necessary to effect a seal.
M = Extra load (above Y factor) necessary to hold fluid pressure over the operational pressure range of the system.

Near zero "m" and "y" factor sealing gaskets can be used effectively on coated flange mating surfaces made from glass, plastics, epoxy, ceramics and other materials that would tend to be damaged when over compressed.

Lower bolt torques required to effect a seal.

- Reduction in installation time and the need for impact wrenches or cheater bars.
- Eliminates the need for retightening due to flat gasket cold flow.
- Reduces the need for high tensile strength bolts or studs.
- Assures a positive seal first time, every time while eliminating costly delays to tighten leaking flanges during initial pressurization.

Increases gasket life.

- The micro-exposure of the seals to any external environment serves to dramatically lengthen the life of the gasket.

Absolutely eliminates cold flow problems.

- The encapsulation of the sealing elements produces a positive

Other high quality sealing gaskets from PSI.

40 YEARS
OF FIELD PROVEN PERFORMANCE
AND RELIABILITY.



After Bolt Tightening

LineBacker® sealing gaskets

utilize a patented rectangular sealing element, referred to as a "quad" ring, in combination with a unique groove design to effectively seal and isolate flanges of all types. With the unique "quad" ring design, elastic memory is provided for elastomers not normally associated with this characteristic.

Note: For more information on the complete line of PSI gaskets, visit www.pipelineseal.com. Download the Sealing Gasket literature.

- cold flow control, there by strengthening their sealing power.
- Sealing elements with high cold flow characteristics now may be used to achieve a superior seal in virtually any media, temperature, pressure or pipe size.

Pressure energized, controlled confinement of PSI sealing elements.

- Sealing elements maintain contact with mating surfaces even though the surfaces may tend to warp or separate due to thermal shock, pressure fluctuations or other external forces.
- Low Pressure Applications - The spring energizes seal.
- High Pressure Applications - The line pressure energizes seal.

Match gasket materials to service conditions.

- Sealing elements may be made of a selection of elastomers.
- Retainers may be made of a variety of dielectric materials.

Sealing elements may be positioned anywhere between the I.D. of the gasket and the I.D. of the bolt circle.

- Allows the ability to use PSI sealing gaskets with ring joint, flat face, raised face or any combination of these flange types in a given size and pressure rating.

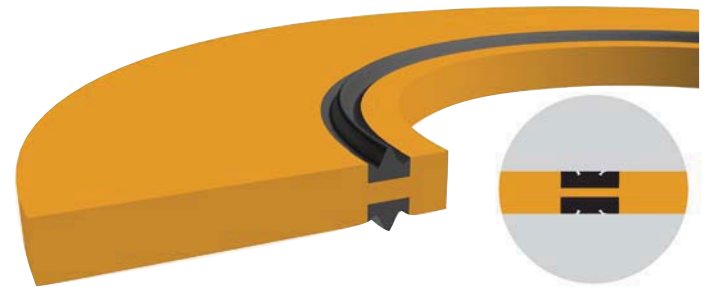

After Bolt Tightening

GasketSeal® sealing gaskets

are considered one of the most effective methods for sealing and isolating flanges of all types. The gasket consists of two molded semi "O" rings (with precise crown to void ratio) mounted in grooves on opposite sides of an isolating retainer. While maintaining all the advantages of a full "O" ring seal, the semi "O" ring seal eliminates the need for a sealing groove in the flange face to reduce problems associated with alignment.

LineSeal™ Material Properties

Common LineSeal Sealing Gasket Physical Properties

ASTM	Test Method	G-10 Epoxy/Glass
D149	Dielectric Strength Volts/Mil (Short Time)	800
D695	Compressive Strength (psi)	69,000
D229	Water Absorption (%)	0.04
D257	Insulation Resistance Meg Ohms	300,000
D790	Flexural Strength (psi)	65,000
D256	IZOD Impact Strength (Ft-Lbs/Inch)	26.0
D638	Tensile Strength (psi)	51,000
D732	Shear Strength (psi)	21,000
	Temperature Range (Degrees F)	Cryogenic to +302
	Temperature Range (Degrees C)	Cryogenic to +150

Seal Element Temperature Limits

	PTFE (Teflon)	Viton
Degrees Fahrenheit	Cryogenic to +450	-20 to +350
Degrees Celsius	Cryogenic to +232	-29 to +177

Note: Consult with a specialist for cryogenic applications and/or extreme temperature variations, hazardous fluids or for extremes in temperatures and pressures.

Suggested Sealing Gasket Material Compatibility

Medium	Retainer	Seal	Temp. Range °F	Temp. Range °C
Carbon Dioxide	G-10	Teflon or Viton	-65 to +250 / -20 to +280	-54 to +121 / -29 to +138
Diesel Fuel	G-10	Teflon or Viton	-65 to +250 / -20 to +280	-54 to +121 / -29 to +138
Ethanol	G-10	Teflon or Viton	-65 to +250 / -20 to +280	-54 to +121 / -29 to +138
Fuel Oil	G-10	Teflon or Viton	-65 to +250 / -20 to +280	-54 to +121 / -29 to +138
H2S	G-10	Teflon	-65 to +250	-54 to +121
Gas, Natural	G-10	Teflon or Viton	-65 to +250 / -20 to +280	-54 to +121 / -29 to +138
Gas, Sweet	G-10	Viton	-20 to +220	-29 to +138
Gas, Sour CO2 Mix	G-10	Teflon	-65 to +250	-54 to +121
Jet Fuel	G-10	Teflon or Viton	-65 to +250 / -20 to +280	-54 to +121 / -29 to +138
Nitrogen	G-10	Teflon or Viton	-65 to +250 / -20 to +280	-54 to +121 / -29 to +138
Oil, Crude	G-10	Teflon or Viton	-65 to +250 / -20 to +280	-54 to +121 / -29 to +138
Propane	G-10	Teflon or Viton	-65 to +250 / -20 to +280	-54 to +121 / -29 to +138
Propylene	G-10	Viton	-20 to +80	-29 to +27
Sewage	G-10	Teflon or Viton	-65 to +250 / -20 to +280	-54 to +121 / -29 to +138
Water (Hot)	G-10	Teflon or Viton	-65 to +250 / -20 to +280	-54 to +121 / -29 to +138
Water (Sea)	G-10	Teflon or Viton	-65 to +250 / -20 to +280	-54 to +121 / -29 to +138

General Notes:

The foregoing performance data are intended as guidelines only. Performance suitability for any specific applications should be determined by the user. Variation in temperature, pressure, concentration or mixtures acting synergistically may preclude suggested service use. Material selection is at the sole risk of the user. Consult with a specialist or PSI factory for specific applications. PSI's responsibilities will be limited to those listed in the PSI standard warranties.

LineSeal Test Results - Typical

Test	LineSeal Value
Compression Test EN 13555 @ 150° C.	140 Mpa Gasket Stress
Creep Relaxation EN 13555 @ 150° C.	0.99 Relaxation Factor
Leakage Test EN 13555 @ 40 bar Helium @ 5 Mpa to 80 Mpa gasket stress	1.0 x 10 ⁻³ mg/m/s Leakage Rate
Hot Blowout Test HOBT @ 151° C. @ 165 bar	No Blowout
Shell Leakage Test T-2.232686 @ ambient @ 52 Mpa	4.2 x 10 ⁻⁷ pa-m ³ /s/mm Leakage Rate
Shell Cycle Test T-2.232686 @ 150° C. @ 45.6 Mpa	< 0.10 bar pressure loss



LineSeal™ Flange Isolation Kits

Single Washer Set

Single washer set flange isolation kits include the following items for each bolt:

- One - 1/8" thick steel washer
- One - Isolating washer
- One - Isolating sleeve

Double Washer Set

Double washer set flange isolation kits include the following components for each bolt:

- Two - 1/8" thick steel washers
- Two - Isolating washers
- One - Full length isolating sleeve

G-10 One-Piece Sleeve and Washer Sets

One-piece sleeve and washer set flange isolation kits include the following items for each bolt:

- One - 1/8" thick steel washer
- One - 1/8" thick G-10 Washer
- One - G-10 Isolating Sleeve

Steel Washers

Steel washers are designed to fit over the isolating sleeve or the retainer ring on the one-piece sleeves and washers. The outside diameter is sized to fit within the bolt facing on ANSI standard flanges. They are made of 1/8" (3.2mm) thick plated hot-rolled steel. (Stainless steel available)

Application Considerations

In buried applications, single washer configurations may be used to allow the Cathodic Protection (CP) current to reach the nuts and bolts. If desired, nuts on the opposite side of the cathodically protected flange may be included as part of the CP system.

Application Considerations

Double washer configurations may be used for added protection against the possibility of "shorting out" the nuts and bolts. In addition, double washer sets electrically isolate the nuts and bolts from both flanges.

Application Considerations

Easier to install, one-piece sleeves also allow the inspector a visual indication of sleeve usage.

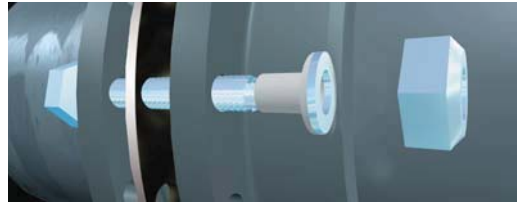
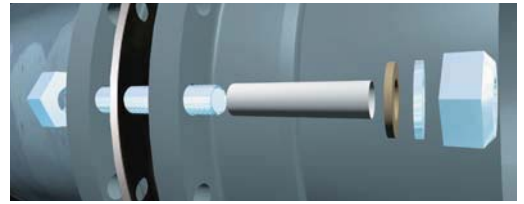

1/8" Washer Material Physical Properties

ASTM Test Method	G-10 Epoxy Glass	G-11 Epoxy Glass
D149 Dielectric Strength Volts/Mil (Short Time)	550	550
D695 Compressive Strength psi	50,000	50 - 80,000
D229 Water Absorption %	0.10	0.10
Operating Temp °F	Cryogenic to +280	Cryogenic to +350
°C	Cryogenic to +138	Cryogenic to +177

Sleeve Material Physical Properties

ASTM Test Method	Mylar	G-10 Epoxy Glass	G-11 Epoxy Glass
D149 Dielectric Strength Volts/Mil (Short Time)	4000	400	400
D695 Compressive Strength psi	N/A	N/A	N/A
D229 Water Absorption %	0.8	0.10	0.10
Operating Temp. °F	-75 to +300	Cryogenic to +280	Cryogenic to +320
°C	-59 to +149	Cryogenic to +138	Cryogenic to +160
D790 Flexural Strength psi	13,000	55,000	55,000
Cut Through Resistance ft-lbs.	3,500	16,000	No Test

Full length sleeve, single washer set configuration

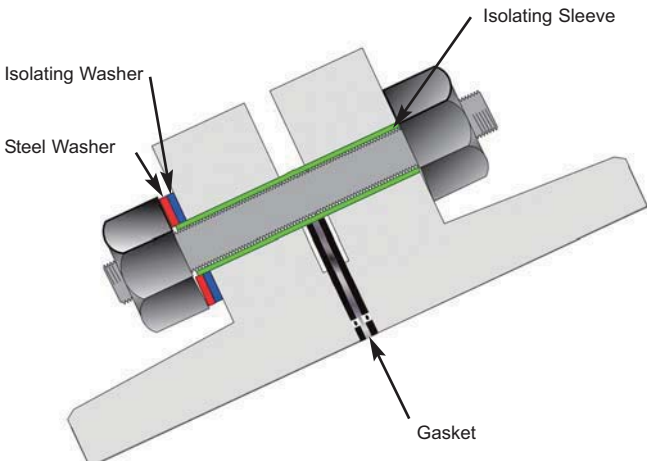

One-piece sleeve & washer configuration

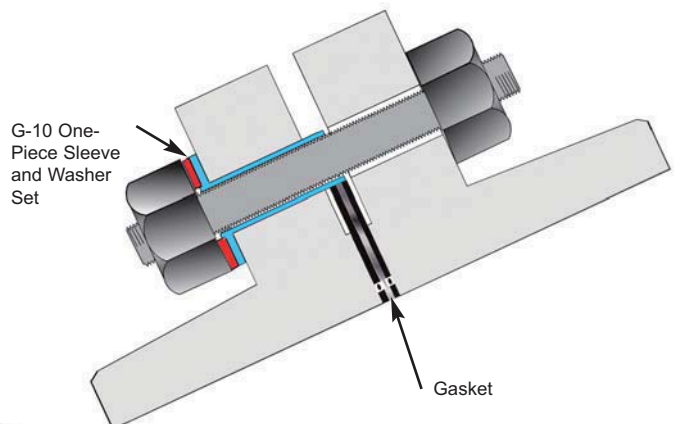

Buried Application Note: Consider using the ElectroStop™ monolithic isolation fitting.



Typical Specification

All Critical Service Applications

Materials for sealing gaskets on pipes containing water, aqueous fluids, oil, sour or natural gas (up to 302°F, 150°C) shall consist of the following components:

Isolation and Sealing Gasket

One isolating and sealing gasket, LineSeal Type "F", 0.27" thick, 316 stainless steel core retainer laminated on both sides with a G-10 fiber glass reinforced laminate containing a precision tapered groove to accommodate the controlled compression of a PTFE(Teflon) spring energized seal. Sealing element placement shall accommodate either flat, raised or RTJ face flanges. The spring energized seal shall be pressure energized. The G-10 retainer shall have a 800 volts/mil dielectric strength and a minimum 69,000 psi compressive strength. The I.D. of the flange isolating gasket shall match the bore of the flange in which it is installed.

Quality

Gaskets shall be manufactured at a facility that has a registered ISO 9001:2008 Quality Management System. Submittals shall include copy of valid registration. Performance suitability and material compatibility shall be determined by the user.

Availability

Gaskets shall be manufactured by Pipeline Seal and Insulator, Inc., Houston, Texas, U.S.A., Telephone: 713-747-6948, Facsimile: 713-747-6029, www.pipeline Seal.com e-mail: info@psipsi.com

Warranty

All products are warranted against failure caused by manufacturing defects for a period of one year. Any product found to be so defective and returned within one year from date of shipment will be replaced without charge.

The above warranty is made in lieu of, and we disclaim, any and all other warranties, expressed or implied, including the warranties of merchantability and fitness for a particular purpose, and buyer agrees to accept the products without any such warranties.

We hereby disclaim any obligation or liability for consequential damages, labor costs or any other claims or liabilities of any kind whatsoever.

Frequently Asked Questions

1. Why would one use a LineSeal™ gasket as opposed to a LineBacker® gasket?

LineSeal gaskets are especially effective for sealing extremely critical flange applications such as high concentrations of H₂S at high pressures where even trace amounts of leakage could prove fatal. The G-10 retainer material is not compromised by exposure to this hazardous fluid while the soft, one-piece sealing elements eliminate any chance of a leakage emanating from between the flange faces.

2. In what applications is the LineSeal gasket considered better than a PSI LineBacker® or GasketSeal® gasket?

Exposure to high temperatures, fluctuating temperatures and/or corrosive fluids is where the Line-Seal gasket proves especially effective at creating and maintaining a seal. The largest portion of the G-10 retainer is totally protected from any fluids by the seal elements which are positioned in close proximity to the barrel of the flange.

3. How do the dielectric characteristics of LineSeal gaskets compare to LineBacker® or GasketSeal® gaskets?

LineSeal gaskets are offered for extreme critical service applications where the need for superior sealing characteristics exceed its electrical isolation characteristics. Any gasket with a metal core is a compromise when compared to a gasket constructed completely from dielectric materials.

4. Is there an environment where a Viton Seal would be preferred over a Teflon® seal?

When fluctuating temperatures are encountered and pressure changes fluctuate across a broad range, the Teflon® seal may lose its pliability over time. Under these conditions, the LineSeal with a spring energized rubber Viton seal element should be considered.

Extreme Critical Sealing for Industries

Production Fields and Offshore

In gathering and injection piping - tank farms - oil and gas processing systems - for sour gas and water handling systems. For Christmas trees - pumps - valves - and wherever it is important to guard against the loss of product.

Petroleum Marketing Facilities

In terminal and tank farm piping - marine and airport fueling systems - and other product handling facilities where it is essential to prevent loss of product or damage due to a flange leak or blowout.

LNG and SNG Systems

For loading, unloading, liquefaction, regasification and processing of LNG - the production and processing of SNG - and wherever it is essential to provide a leak-proof flange for use from cryogenic to very high temperatures.

Pipeline and Distribution Piping

In compressor and pumping station piping - metering and measurement facilities - valves and other control equipment - and elsewhere on a mainline piping system where a long-lasting, leak-proof flange is essential. In gas distribution piping - underground storage facilities - town border stations - industrial meter-regulator sets - and district regulators.

Refineries

In piping systems for heavy gasoline - caustic - acid based materials - carbon slurry - and wherever it is essential to protect plant and personnel from damage due to flange leaks or blowouts.



PSI LineSeal™ Flange Isolation Ordering Guide/Worksheet

Quantity	Nominal Pipe Size	ANSI Class	Gasket Type	Gasket Style	For LineSeal™ Sealing Gaskets	Washers	Washer Material	Sleeve	Gasket I.D. Schedule Pipe Flange	Type
Specify Below	Specify Below	150# 300# 400# 600# 900# 1500# 2500#	E = With Bolt Holes F = Ring (No Bolt Holes)	LS = LineSeal	Retainer G-10 G-11 Seal Element Viton Teflon Nitrile	SW = Single Washers DW = Double Washers	G-10 1 PC G-10 G-11	Mylar G-10 G-11	Specify Below	W = Weld Neck S = Slip On R = RTJ BX = API BX RX = API RX O = Other Denote Specs. and Table

Quantity	Nominal Pipe Size	ANSI Class	Gasket Type	Gasket Style	For LineSeal™ Sealing Gaskets	Washers	Washer Material	Sleeve	Gasket I.D. Schedule Pipe Flange	Type
_____	_____	_____	_____	_____	Retainer _____ Seal Element _____	_____	_____	_____	_____	_____
_____	_____	_____	_____	_____	_____	_____	_____	_____	_____	_____
_____	_____	_____	_____	_____	_____	_____	_____	_____	_____	_____
_____	_____	_____	_____	_____	_____	_____	_____	_____	_____	_____



Flange Faces > 250 Micro Inches: For flange face surfacing greater than 250 micro inches, consult factory.

For Flange Isolation Kits over 24" in addition to the above please specify:

Flange Facing <small>(Raised, RTJ, etc)</small>	_____	Nominal Bolt Diameter <small>(Threads/Inch)</small>	_____
Flange I.D.	_____	Sleeve Length	_____
Flange O.D.	_____	Pipe I.D.	_____
Flange Thickness	_____	Steel Sleeve I.D. <small>(For Concrete Pipe)</small>	_____
Number of Studs/Bolts	_____	Product In Line	_____
Stud/Bolt Diameter	_____	AWWA Class & Table <small>(Or other similar std.)</small>	_____
Stud/Bolt Hole Diameter	_____	Internal Lining	_____
Stud/Bolt Circle Diameter	_____		_____

Note: Caution! Bolts with smooth shank portions may not fit within sleeves. Verify prior to ordering.



How to Order

Please provide the following information:

1. Quantity
2. Nominal Pipe Size
3. Pressure Rating
4. Gasket Type: F and E
5. Gasket Style: LS
6. Retainer Material
7. Sealing Element
8. Gasket I.D. or SCH.
9. Weld-neck, Slip-on, R.T.J or Integral applications
10. Note all special requirements
11. Contact your local distributor or PSI

ISO 9001:2008 Quality Assurance

All PSI facilities are ISO 9001:2008 certified with extensive quality control procedures in effect to insure total compliance with product performance and reliability standards. In addition, all PSI gaskets are clearly marked with the following information to guarantee that the correct gasket is used for its intended application.

- Brand Name
- Material Make-up (retainer/seal element)
- Pipe Size
- Pressure Rating
- Date of Manufacture Stamp

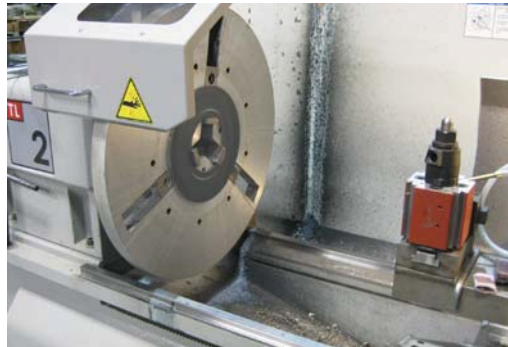

PSI's Water Jet and CNC Machines

PSI's water jet machinery cut intricate parts with no heat-affected zone, distortion, or mechanical stresses caused by other cutting methods. In addition, they cut with a narrow kerf, to provide better usage of raw material. As a result PSI has the ability to provide more accurate gaskets, with more intricate shapes and possibilities without wasting raw materials. CNC machines cut precise dimensions to accommodate specific seal elements and gasket tolerances.

ElectroStop® Monolithic Isolation Fittings...Alternative to Flange Isolation Kits.

The ElectroStop monolithic isolation fitting will serve as a positive leak proof, long lasting block against the flow of electric current in all piping systems. When you bury the ElectroStop isolation fitting you bury maintenance costs forever - an especially important feature for system operators and engineers.

The Industry's "Dual 'O' Ring Seal"

Standard Test Include:

- 100% Hydrostatic Pressure & Electrical tests
- 100% Ultrasonic of Welds
- 100% Magnetic Particle of Welds
- 100% Dye Penetrant of Welds



Pipeline Seal and Insulator, Inc.

6525 Goforth Street, Houston, TX 77021 U.S.A.
Toll Free: 800-423-2410 Telephone: 713-747-6948
Facsimile: 713-747-6029
e-mail: info@psipsi.com
www.lineal.com
www.pipelineal.com

Canadian Supplier
Power Plant Supply Co
416 752 3339
902 435 9899
709 747 7650

<http://www.powerplantsupplyco.com>

